

# NOVA PRO SCALA

## Pot drawer H90 with rectangular railing

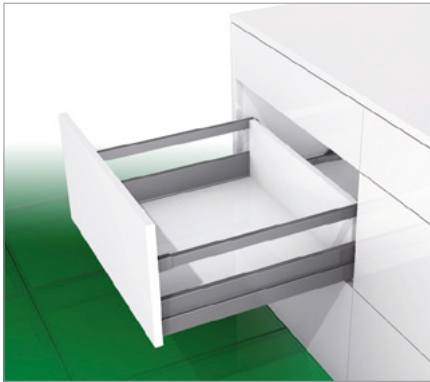

- Snug-fitting rectangular railing
- Flush-fitting back panel adapter
- Minimum plastic parts
- Integrated height and side adjustment
- Tilt angle adjustment using railing
- Optimum use of space due to straight inside surfaces and low construction width
- Tool-free installation and removal of the front
- Width of bottom and back panel is the same
- Bottom panel machining not required

### Packaging unit (PU):

- 123 = 100 items in PE
- 201 = 1 item in cardboard box (smallest PU = 10 units)
- 211 = 20 items in a cardboard box
- 228 = 150 items in a cardboard box
- 250 = 1500 items in a cardboard box
- 328 = 150 units in reusable packaging (cardboard box)
- 507 = 10 items in PE in a cardboard box
- 547 = 1000 items in PE in a cardboard box

## ORDER INFORMATION

### 1 Nova Pro Scala drawer sides H90 Set: One left, one right

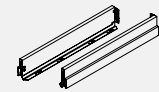

NL	Stone				Ice				Silver			
	Art.-no.	PU		Art.-no.	PU		Art.-no.	PU				
270	F100103108	201	211	F100103135	201	211	F100103162	201	211			
300	F100103111	201	211	F100103138	201	211	F100103165	201	211			
350	F100103114	201	211	F100103141	201	211	F100103168	201	211			
400	F100103117	201	211	F100103144	201	211	F100103171	201	211			
450	F100103120	201	211	228	F100103147	201	211	228	F100103174	201	211	228
500	F100103123	201	211	328	F100103150	201	211	328	F100103177	201	211	228
550	F100103126	201	211	F100103153	201	211	F100103180	201	211			
600	F100103129	201	211	F100103156	201	211	F100103183	201	211			
650	F100103132	201	211	F100103159	201	211	F100103186	201	211			

### 2 Rectangular railing, screw-on, for wooden back panel Set: Railing, railing bracket (front/back) and cover cap, one of each left/right

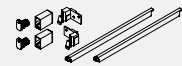

NL	Stone				Ice				Silver			
	Art.-no.	PU		Art.-no.	PU		Art.-no.	PU				
270	F102103516	507		F102103525	507		F102103534	507				
300	F102103517	507		F102103526	507		F102103535	507				
350	F102103518	507		F102103527	507		F102103536	507				
400	F102103519	507		F102103528	507		F102103537	507				
450	F102103520	507		F102103529	507		F102103538	507				
500	F102103521	507		F102103530	507		F102103539	507				
550	F102103522	507		F102103531	507		F102103540	507				
600	F102103523	507		F102103532	507		F102103541	507				
650	F102103524	507		F102103533	507		F102103542	507				

### 3 Installation hook Single item: Can be used on left/right



	Description	Art.-no.	PU	
32 mm	Expansion dowel	F102117719	123	547
50 mm	Expansion dowel	F102117720	123	547
32 mm	For press fitting	F102021854	123	250
50 mm	For press fitting	F102021153	123	250
	For screw fixing	F102021855	123	547

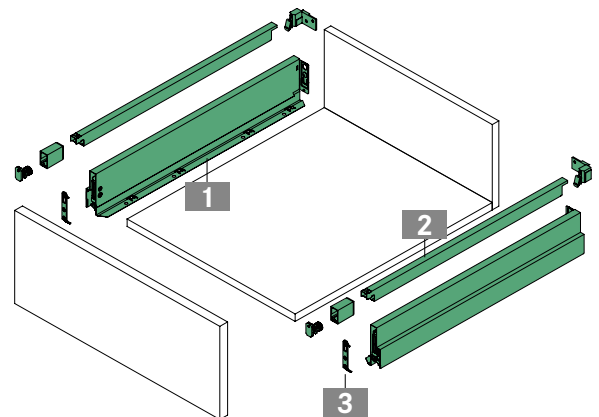

## PAGE REFERENCES

Slides	34	Steel back panels	58	Technical information	74
Inset panels	42	Designer panels	64	Sensomatic	81
Individual components	52	Accessories	66	Organising systems	103

