

# NOVA PRO SCALA

## Drawers H63

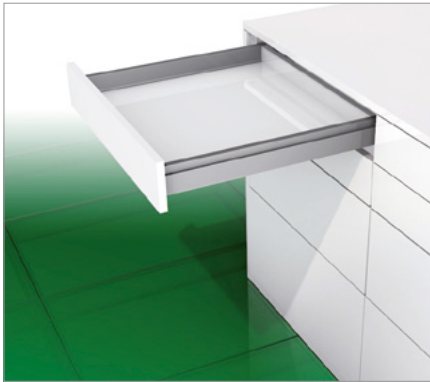

- Extremely low drawer for limited heights
- Can be personalised with designer panels
- Integrated height and side adjustment
- Optimum use of space due to straight inside surfaces and low construction width
- Robust design and high level of stability
- Tool-free installation and removal of the front
- Width of bottom and back panel is the same
- Bottom panel machining not required

### Packaging unit (PU):

- 123 = 100 items in PE
- 201 = 1 item in cardboard box (smallest PU = 10 units)
- 211 = 20 items in a cardboard box
- 250 = 1500 items in a cardboard box

## ORDER INFORMATION

- 1** Nova Pro Scala drawer sides H63  
Set: One left, one right

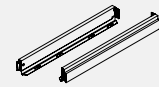

NL	Stone				Ice				Silver				
	Art.-no.	PU		Art.-no.	PU		Art.-no.	PU					
400	F100103009	201	211	F100103036	201	211	F100103063	201	211				
450	F100103012	201	211	F100103039	201	211	F100103066	201	211				
500	F100103015	201	211	F100103042	201	211	F100103069	201	211				
550	F100103018	201	211	F100103045	201	211	F100103072	201	211				

- 2** Installation hook  
Single item: Can be used on left/right



Description	Art.-no.	PU	
Expansion dowel	F102117716	123	
For press fitting	F102038331	123	250
For screw fixing	F102038330	123	

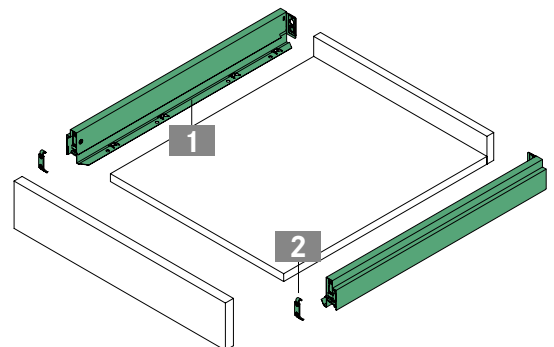

## PAGE REFERENCES

Slides	34	Accessories	66	Assembly technology	116
Steel back panels	58	Technical information	74	Assembly aids	120
Designer panels	64	Sensomatic	81	Packaging code	127

## PLANNING DIMENSIONS

All dimensions in millimetres

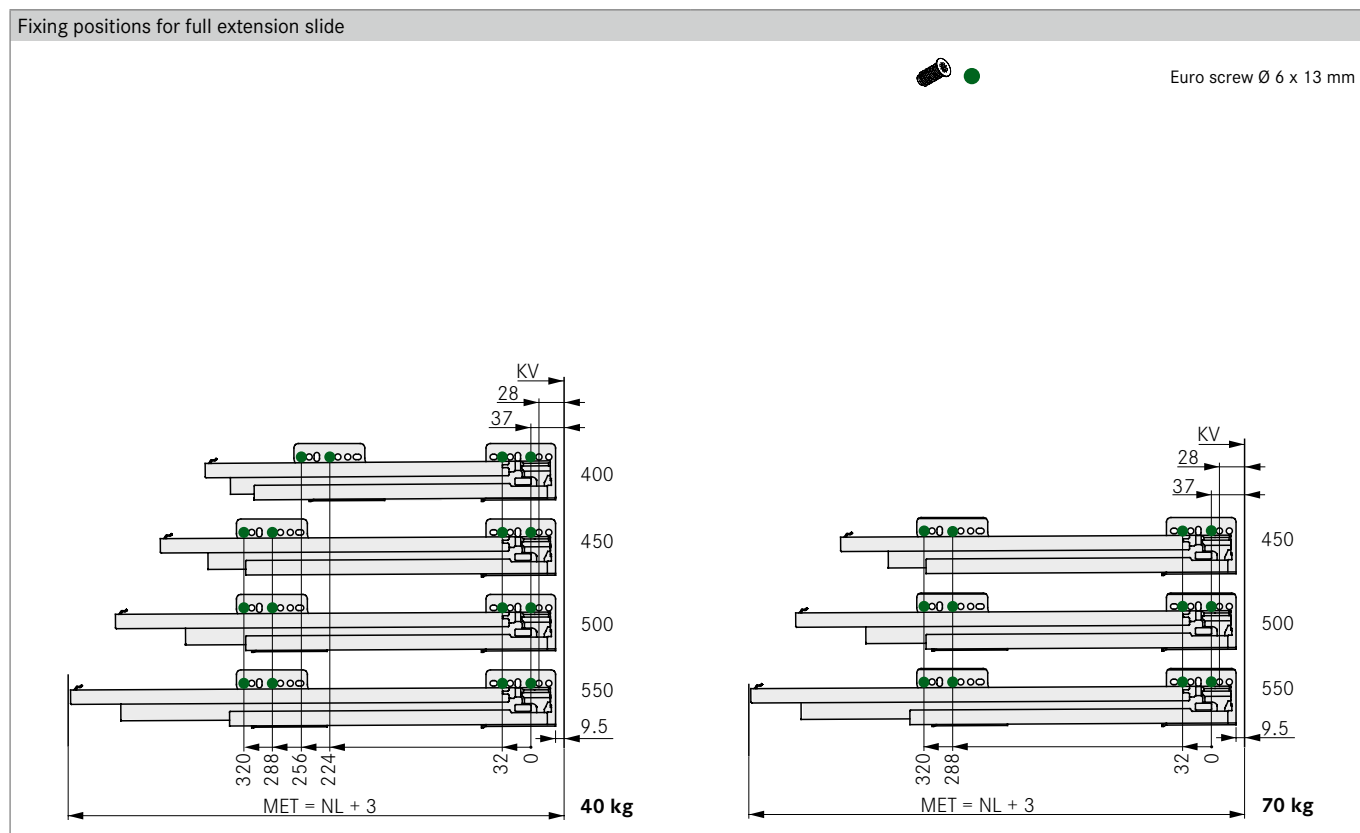
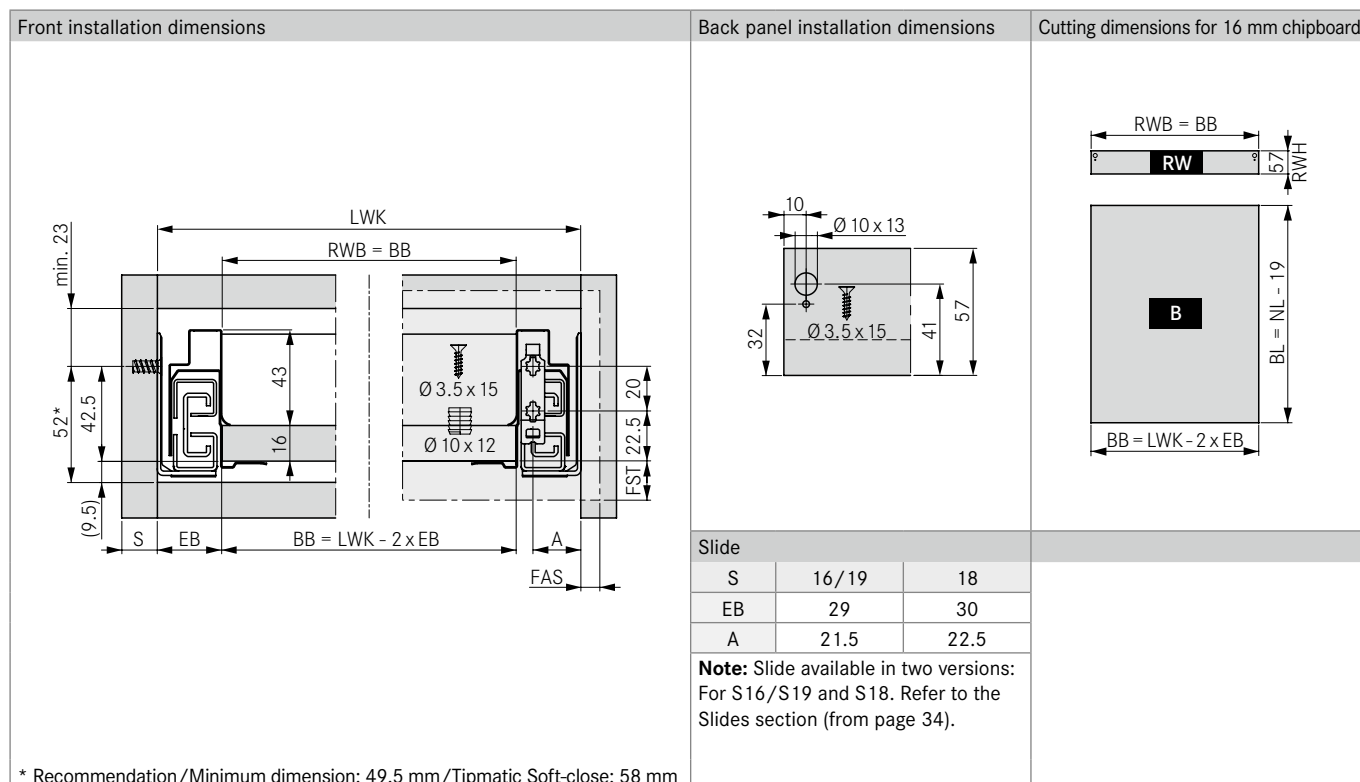

## LEGEND

B	Bottom panel	FST	Front overlay	NL	Nominal length
BB / BL	Bottom width / Bottom length	KV	Front edge of cabinet	RW	Back panel
EB	Construction width	LWK	Inside cabinet width	RWB	Width of back panel
FAS	Front overlay, side	MET	Minimum installation depth	RWH	Height of back panel